



Instructions for Installation of Industrial and Commercial Inverters in Different Scenarios

SUNGROW

Contents

- 1 Document Overview 1**
 - 1.1 Introduction 1
 - 1.2 Applicability..... 1
 - 1.3 Target Audience 1
 - 1.4 Use of Symbols 2
- 2 Installation Requirements..... 3**
 - 2.1 Safety Precautions..... 3
 - 2.2 Installation Environment Requirements 5
- 3 Vertical Rack Mounting 6**
 - 3.1 Mounting Under the Module..... 6
 - 3.1.1 Application scenario 6
 - 3.1.2 Spacing requirements..... 6
 - 3.2 Mounting Near the Module..... 7
 - 3.2.1 Application scenario 7
 - 3.2.2 Precautions..... 8
 - 3.2.3 Spacing requirements..... 8
 - 3.3 Back to Back Installation 9
 - 3.3.1 Application scenario 9
 - 3.3.2 Spacing requirements..... 9
 - 3.4 Floating Power Plant 10
 - 3.4.1 Application scenario 10
 - 3.4.2 Precautions..... 10
 - 3.4.3 Center of gravity..... 10
 - 3.4.4 Special requirements for fixed cables..... 13
- 4 Wall Mounting..... 15**

- 4.1 Application scenario 15
- 4.2 Installation spacing requirements..... 15
 - 4.2.1 Spacing for installing an inverter 15
 - 4.2.2 Spacing for installing more than one inverter 16
- 5 Flat Installation..... 19**
- 5.1 Application scenario 19
- 5.2 Rack preparation 19
 - 5.2.1 Rack requirements 19
 - 5.2.2 Rack dimensions 20
- 5.3 Installation spacing requirements..... 20
 - 5.3.1 Spacing for installing an inverter 20
 - 5.3.2 Spacing for installing more than one inverter 21
- 6 Sunshade..... 23**
- 6.1 Top sunshade 23
 - 6.1.1 Precautions 23
 - 6.1.2 Sunshade dimensions..... 23
- 6.2 Flat Sunshade..... 24
 - 6.2.1 Precautions 25
 - 6.2.2 Sunshade dimensions..... 25
- 7 Appendix..... 28**
- 7.1 Uncovering 28
- 7.2 Fan Maintenance 28
- 7.3 Spacing requirements for installing other devices 31

1 Document Overview

1.1 Introduction

This document describes the precautions and installation requirements of industrial and commercial inverters in several scenarios, including vertical rack installation, wall installation, and flat installation. Please read this document carefully before installing the inverter.

Without the consent of Sungrow Power Supply Co., Ltd., no part of this document may be distributed, reproduced, or disclosed to a third party or uploaded to a third party platform such as a public network.

This document is the V1.0 version officially archived, and the updated version shall prevail if any subsequent optimizations are made.

1.2 Applicability

This document is intended for the following devices.

- SG25CX-SA
- SG30CX
- SG33CX
- SG40CX
- SG50CX
- SG36CX-US
- SG60CX-US
- SG100CX
- SG110CX
- SG136TX

1.3 Target Audience

The inverter can only be installed by professional technicians. The professional technicians shall meet the following requirements:





- They have received the relevant training.
- They have read this document thoroughly and understand the safety precautions related to the operations.

- They are familiar with local standards and relevant safety regulations for electrical systems.

1.4 Use of Symbols

To ensure the safety of the persons and property of users when they use the product and to make sure that the product is used in an optimal and efficient manner, this manual provides users with the relevant safety information highlighted by the following symbols.

The symbols used in this document are listed below. Please pay attention to them while reading to make better use of this document.

Symbol	Description
	Indicates an imminently hazardous situation which, if not avoided, will result in death or serious injury.
	Indicates a moderately hazardous situation which, if not avoided, may result in death or serious injury.
	Indicates a slightly hazardous situation which, if not avoided, may result in minor or moderate injury.
NOTICE	Indicates a potential hazard which, if not avoided, may result in device malfunction or property damage.
	Indicates content added for emphasis or to provide supplemental information. This can include tips or tricks for product optimization, which can help you solve a problem or save time.

2 Installation Requirements

2.1 Safety Precautions

Danger

Before installing, check whether the inverter was damaged during transportation and ensure that the inverter has no electrical connections.

Danger

Before making any electrical connections, make sure that the photovoltaic string is covered with opaque materials or the circuit breaker on the DC side is disconnected. Exposing the photovoltaic string to sunlight will generate hazardous voltage!

Danger

Before performing any maintenance operations, the following steps must be followed:

- First, disconnect the AC circuit breaker on the grid side, and then disconnect the DC switch.
- Wait for at least 5 minutes until all electricity has been discharged from the internal battery storage components before any maintenance or repair work is carried out inside the equipment.
- Test with a tester to make sure that there is no voltage or current.

Warning

The inverter can only be installed by professional technicians.

- The cables used in the PV generation system must be firmly connected, in good condition, well insulated, and of appropriate specifications.

⚠ Caution**Danger of burns!**

While the inverter is in operation, only the DC switch can be touched. Never touch hot parts of the device (such as the radiator) during operation.

⚠ Caution

The inverter can be handled manually or by hoisting, depending on site conditions.

Improper handling may cause injury!

- **We recommend that the inverter be handled by at least two installers who wear protective equipment such as smash-proof shoes and gloves.**
- **Attention must be paid to the center of gravity of the inverter to avoid tilting during handling.**

When hoisting the inverter, always maintain its balance to avoid collision with walls or other obstacles. In case of bad weather, such as heavy rain, fog, or wind, hoisting shall be stopped.

⚠ Caution

Poor ventilation in the installation environment will affect system performance!

- **The heat sink of the device must not be covered to ensure sufficient cooling inside the device.**

NOTICE

All electrical connections must comply with local and national electrical standards.

The inverter can be connected to the grid only after obtaining the permission of the local electricity department.

NOTICE

The inverter can be restarted only after the faults affecting the safety performance of the inverter are eliminated.

NOTICE

Touching the PCB or other static-sensitive devices may cause damage to the device.

- **Do not touch the circuit board unless absolutely necessary.**
- **Observe the electrostatic protection norms and wear an anti-static wrist strap.**

2.2 Installation Environment Requirements

- The installation environment must be free of flammable or explosive materials.
- Keep the inverter out of reach of children.
- The inverter should be protected from direct sunlight, rain, and snow.
- The inverter shall be installed on a support with a maximum load-bearing capacity more than 4 times the weight of the inverter.
- The temperature and humidity shall be within the working temperature range and working humidity range of the inverter.
- The inverter shall be mounted at a height that makes the LED light indicator panel legible and the switch easy to use.
- The inverter produces noise while in operation, so we do not recommend installation in residential areas.
- The inverter shall be mounted in the area where there is no interference from other power and electronic equipment.
- The inverter cannot be installed in salt stress areas, e.g. coastal areas within 500m from the coast. The amount deposited by a salt fog is correlated to the characteristics of the sea water, winds, precipitation, air humidity, topography, and forest coverage of adjacent water bodies or seas. As a result, there are substantial differences between different coastal areas.

3 Vertical Rack Mounting

The inverter can be mounted directly on a vertical rack, or be installed on the column by using a clamp.

3.1 Mounting Under the Module

3.1.1 Application scenario

This mounting method is commonly used in ground-based distributed power plants. Usually, the inverter is mounted directly on the fixed support of the module or mounted on the column under the module by using a clamp.



3.1.2 Spacing requirements

The inverter shall be installed in an area where there is sufficient space to ensure proper ventilation.

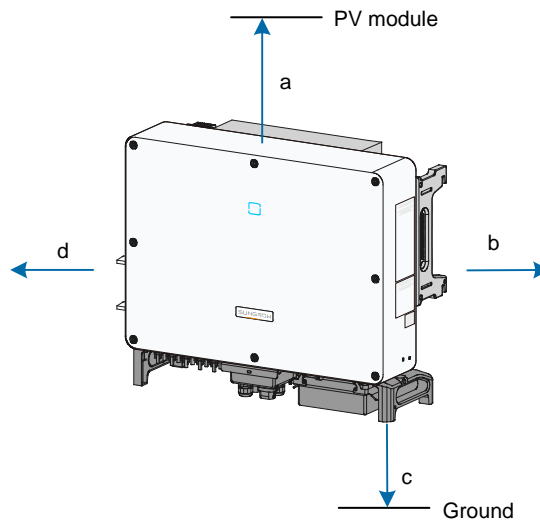

Table 3-1 Minimum mounting spacing (unit: mm)

Model	Top (a)	Right (b)	Bottom (c)	Left (d)
SG25CX-SA	500	200	650	600*
SG30/33/40/50CX				
SG36/60CX-US	500	200	650	450*
SG100/110CX	600	400	450	800*
SG136TX				

*The spacing can be reduced to 200mm according to site conditions. When the spacing is less than that specified in the table, the inverter must be lifted off the rack before fan maintenance operations.

3.2 Mounting Near the Module

3.2.1 Application scenario

This mounting method is common in large-scale industrial and commercial plants or complex hillside power plants. To reduce cable costs, the photovoltaic inverter is suspended on a standalone rack, which is installed near the module.



3.2.2 Precautions

- The inverter shall be sited in such a way that the inverter's shadow will not block the modules under various lighting conditions.
- We recommend that you add a sunshade to the inverter to avoid exposure to the sun. This will increase the yield and extend the life of the inverter.

3.2.3 Spacing requirements

The inverter shall be installed in an area where there is sufficient space to ensure proper ventilation.

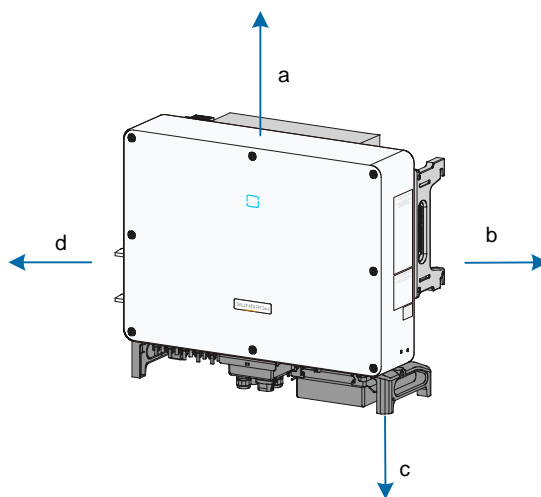

Table 3-2 Minimum mounting spacing (unit: mm)

Model	Top (a)	Right (b)	Bottom (c)	Left (d)
SG25CX-SA SG30/33/40/50CX	500	200	650	600*
SG36/60CX-US	500	200	650	450*
SG100/110CX SG136TX	600	400	450	800*

*The spacing can be reduced to 200mm according to site conditions. When the spacing is less than that specified in the table, the inverter must be lifted off the rack before fan maintenance operations.

3.3 Back to Back Installation

3.3.1 Application scenario

This mounting method is common in small ground power plants or distributed roofs. Photovoltaic inverters are installed back to back on hanging plates in order to reduce cable costs and save installation space.



3.3.2 Spacing requirements

When installing the inverters back to back, the spacing shall be at least 500mm (recommended).

If the spacing requirements cannot be satisfied, a baffle shall be added between the two inverters to create a heat dissipation channel (not recommended). The baffle is placed

horizontally between the two inverters and cannot block the air outlet.

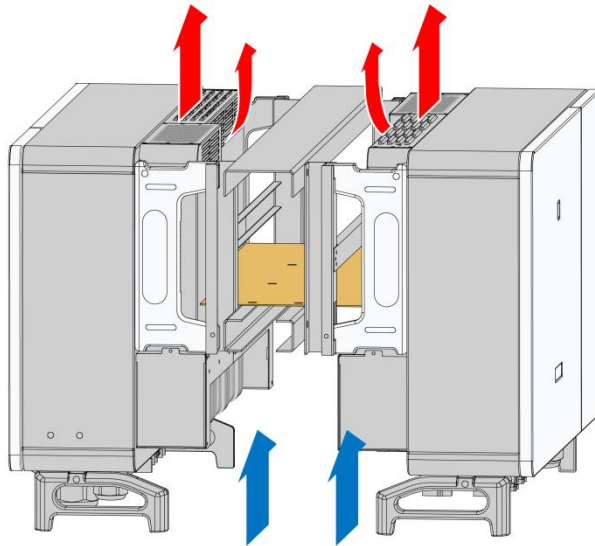

3.4 Floating Power Plant

3.4.1 Application scenario

Floating power plants mainly generate power through photovoltaic modules installed on water platforms formed in ponds, small and medium-sized lakes, reservoirs, impounding reservoirs, and coal mining subsidence areas.

Inverters installed on a floating body shall be suspended vertically on a rack.

3.4.2 Precautions

- Pay attention to the installation of the floating platform for electrical equipment. Due to the deadweight of the platform and electrical equipment and the limited water depth on the shore, it is necessary to select a crane with the right tonnage and lifting radius according to the site conditions.
- During installation, pay attention to protecting the floating platform to avoid collision and damage to the anticorrosive coating.
- The shadow of the photovoltaic modules on the surrounding floating body should be taken into consideration.
- We recommend that you add a sunshade to the inverter to avoid exposure to the sun. This will increase the yield and extend the life of the inverter.

3.4.3 Center of gravity

You shall not install the inverter horizontally. It must be installed vertically on a floating body.

The inverter can be fixed in place according to its center of gravity.

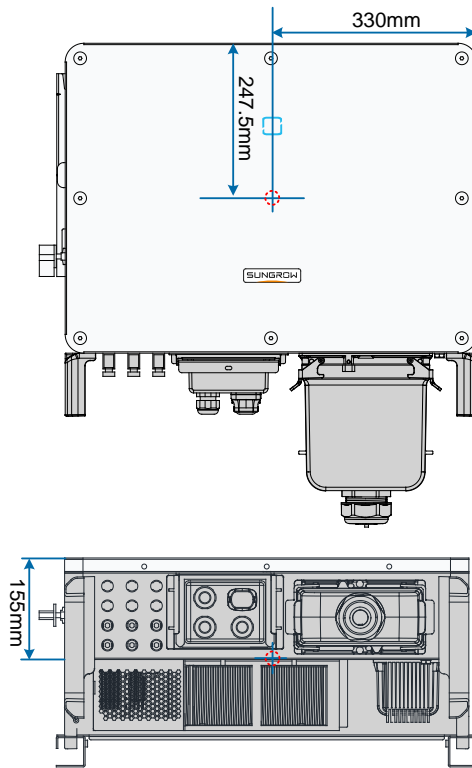

Fig. 3-1 SG30/33CX center of gravity (unit: mm)

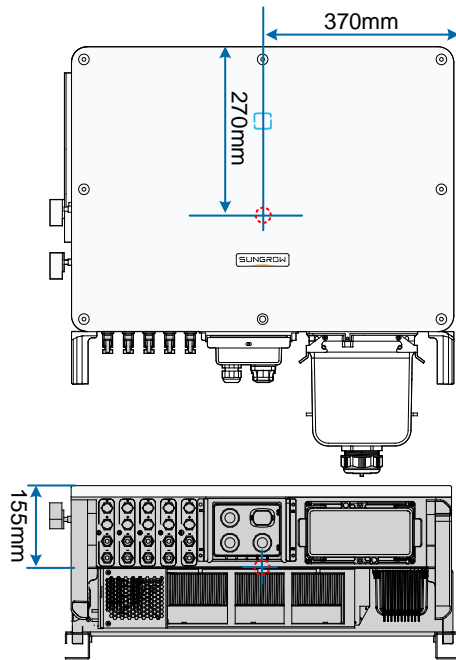

Fig. 3-2 SG25CX-SA/SG40CX/SG50CX center of gravity (unit: mm)

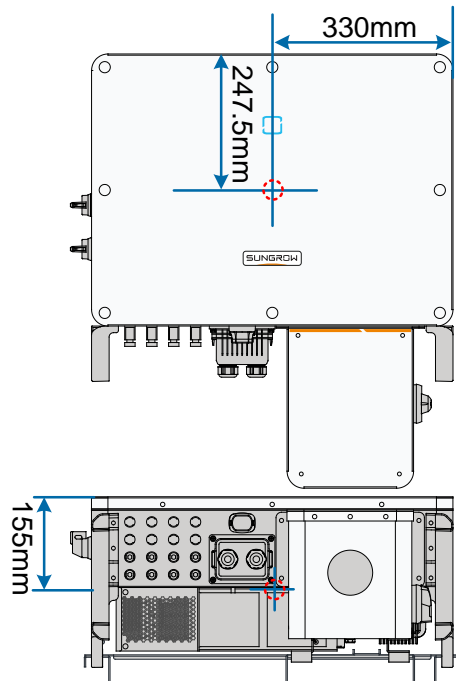

Fig. 3-3 SG36CX-US center of gravity (unit: mm)

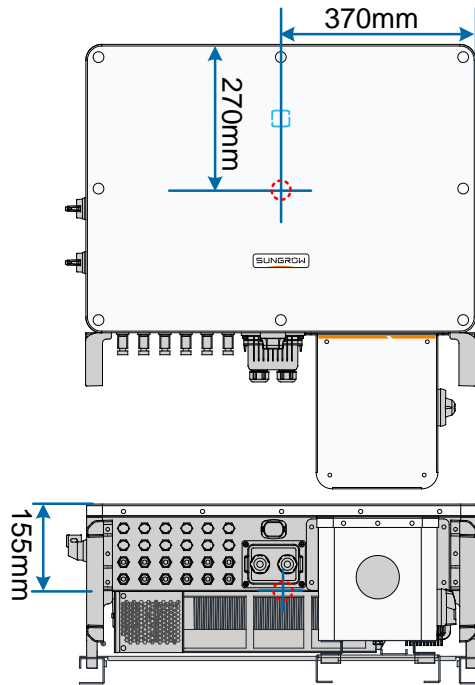

Fig. 3-4 SG60CX-US center of gravity (unit: mm)

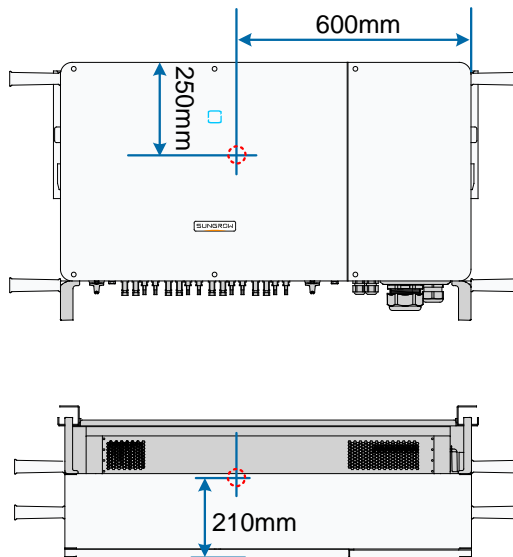

Fig. 3-5 SG60CX-US center of gravity (unit: mm)

3.4.4 Special requirements for fixed cables

The AC cable enters the AC terminal vertically, and the vertical length of the cable is $\geq 200\text{mm}$.

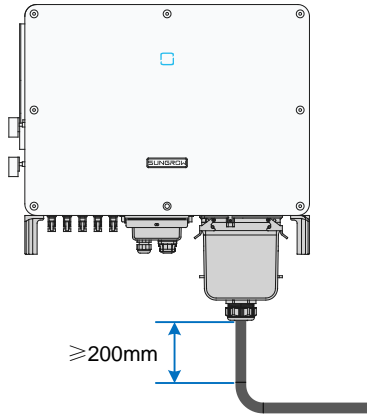

Fig. 3-6 SG25CX-SA/SG30CX/SG33CX/SG40CX/SG50CX

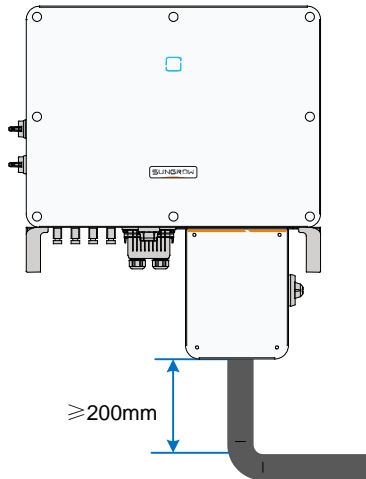

Fig. 3-7 SG36/60CX-US

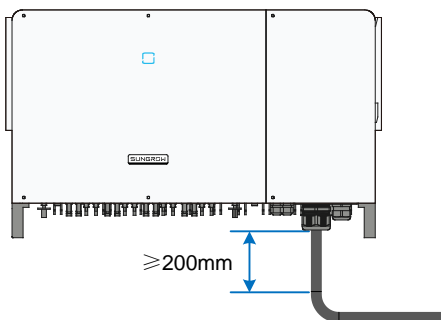

Fig. 3-8 SG100CX/SG110CX/SG136TX

In order to reduce the relative displacement of the cable, the support, and the floating body, it is necessary to fix the cable on the floating body where the inverter is located.

4 Wall Mounting

4.1 Application scenario

This is common in distributed rooftop or indoor installation scenarios. When installing on a wall, install it on the side of the wall not facing the sun if at all possible to avoid direct sunlight and install a sunshade if necessary.



4.2 Installation spacing requirements

The following spacing requirements are set out to meet the heat dissipation, installation, and maintenance requirements. When electricity meters, small distribution boxes, and other devices need to be installed near the inverter, the spacing can be designed with reference to the space requirements in the appendix.

4.2.1 Spacing for installing an inverter

The inverter shall be installed in an area where there is sufficient space to ensure proper ventilation.

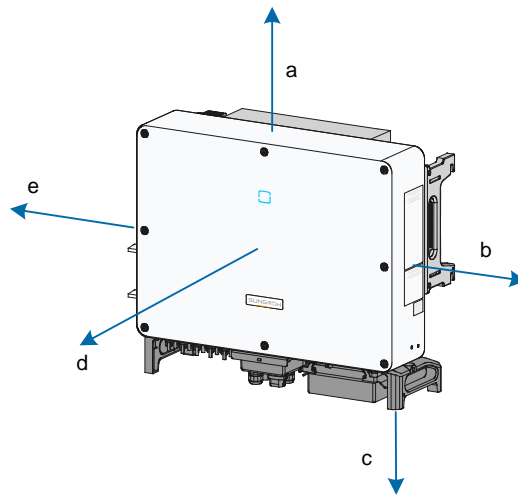

Table 4-1 Minimum mounting spacing (unit: mm)

Model	Top (a)	Right (b)	Bottom (c)	Front (d)	Left (e)
SG25CX-SA	500	200	650	1000	600*
SG30/33/40/50CX					
SG36/60CX-US	500	200	650	1000	450*
SG100/110CX	600	400	450	1000	800*
SG136TX					

*The spacing can be reduced to 200mm according to site conditions. When the spacing is less than that specified in the table, the inverter must be lifted off the wall before fan maintenance operations.

4.2.2 Spacing for installing more than one inverter

To install more than one inverter, inline installation is recommended when there is sufficient space, while top and twin-side bottom installation is recommended when there is limited space. We do not recommend you install multiple inverters on top of each other.

Inline installation (recommended)

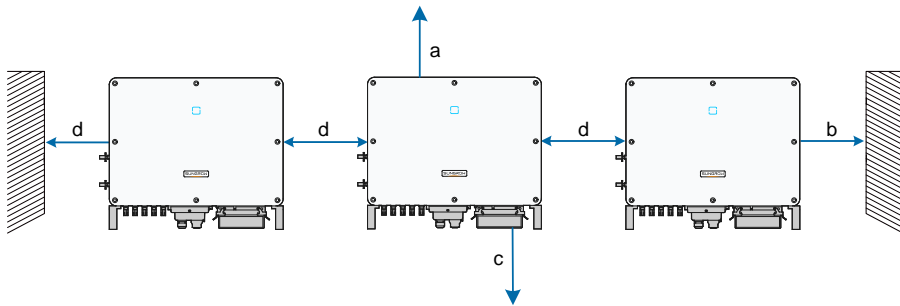

Table 4-2 Minimum spacing for inline installation (unit: mm)

Model	Top (a)	Right (b)	Bottom (c)	Middle (d)
SG25CX-SA	500	200	650	600
SG30/33/40/50CX				600
SG36/60CX-US	500	200	650	450
SG100/110CX	600	400	450	800
SG136TX				800

Top and twin-side bottom installation (recommended)

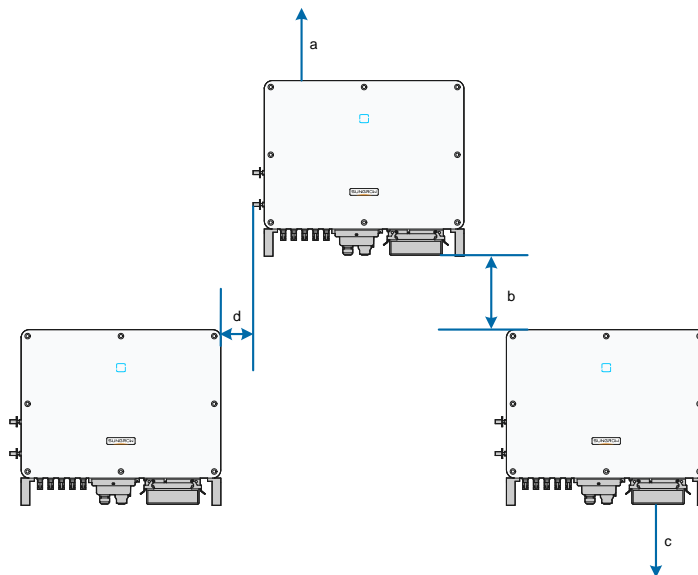

Table 4-3 Minimum spacing for top and twin-side bottom installation (unit: mm)

Model	Top (a)	Top and bottom spacing (b)	Bottom (c)	Left and right spacing (d)
SG25CX-SA				
SG30/33/40/50CX	500	650	650	300
SG36/60CX-US				
SG100/110CX	600	600	450	300
SG136TX				

Stacking installation (not recommended)

NOTICE
 Considering that the inverter dissipates heat through the upper and lower air outlets, the vertical stacking installation method only supports rack installation (where the back of the inverter is not blocked) and does not support wall-mounting scenarios.

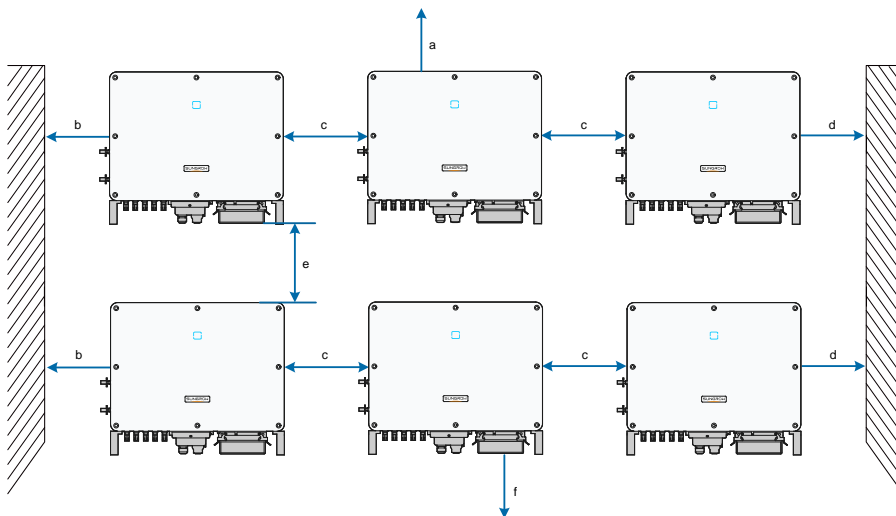

Table 4-4 Minimum spacing for stacking installation (unit: mm)

Model	Top (a)	Left (b)	Middle (c)	Right (d)	Top and bottom spacing (e)	Bottom (f)
SG25CX-SA						
SG30/33/40/50CX	500	450	450	200	650	650
SG36/60CX-US						
SG100/110CX	600	800	800	400	650	400
SG136TX						

5 Flat Installation

5.1 Application scenario

This mounting method is common in scenarios such as concrete roofs or colored steel tile roofs of the plant, where the inverter is nearly lying flat. In such cases, the inverter shall be installed on a flat mounting rack to meet the installation angle requirements. Flat installation is not suitable for floating power plants.

5.2 Rack preparation

SUNGROW provides a flat mounting rack. You can order it from SUNGROW if necessary, or design your own according to the rack requirements.

To order a rack from SUNGROW, please provide the product model or rack code.

Model	Rack No.
SG30/33/40/50CX	B-B-003150
SG36/60CX-US	B-B-003742
SG100/110CX	B-B-003140

5.2.1 Rack requirements

The following factors should be considered when designing the rack scheme:

- Consideration should be given to the climatic conditions at the site, and measures such as protection against rain and snow should be taken when necessary.
- The inverter shall be installed in such a way that the inclination angle between the inverter and the horizontal ground is $\geq 10^\circ$.
- The vertical spacing between the waterproof connector and the ground shall be $\geq 300\text{mm}$.
- Cable binding and fixing shall be done at a distance of 300-350mm from the DC connector, AC connector, and communication waterproof connector in order to avoid cable sagging and shaking, which may result in loose waterproof connectors and affect the product's protection grade.

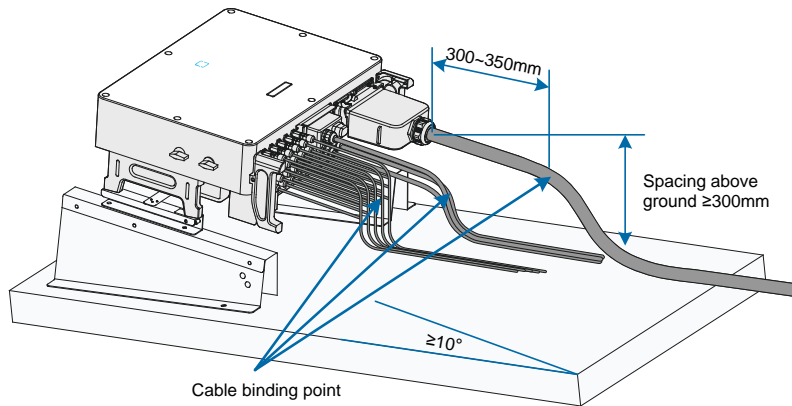

5.2.2 Rack dimensions

To ensure that the requirements of the rack can be met, the rack can be designed with reference to the following diagram.

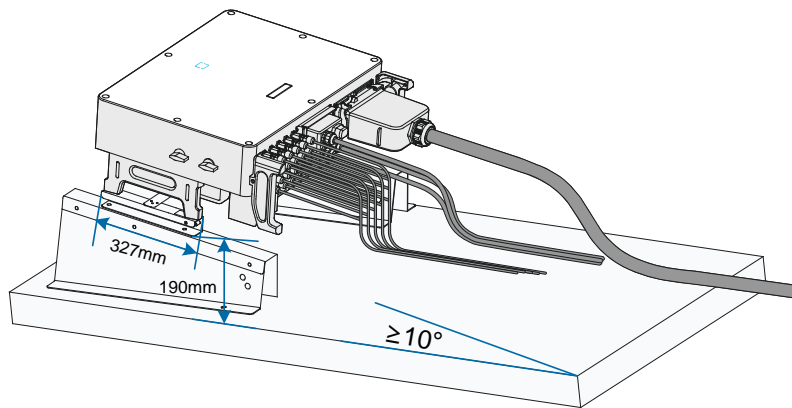

5.3 Installation spacing requirements

The following spacing requirements are proposed to satisfy the requirements of heat dissipation, installation, and maintenance.

5.3.1 Spacing for installing an inverter

The inverter shall be installed in an area where there is sufficient space to ensure proper ventilation.

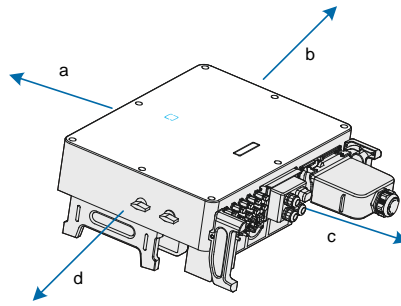

Table 5-1 Minimum mounting spacing (unit: mm)

Model	Top (a)	Right (b)	Bottom (c)	Left (d)
SG25CX-SA	500	200	650	600*
SG30/33/40/50CX				
SG36/60CX-US	500	200	650	450*
SG100/110CX	600	400	450	800*
SG136TX				

*The spacing can be reduced to 200mm according to site conditions. When the spacing is less than that specified in the table, the inverter must be lifted off the rack before fan maintenance operations.

5.3.2 Spacing for installing more than one inverter

To install more than one inverter, inline installation is recommended when there is sufficient space, while front and rear installation is recommended when there is limited space.

Inline installation (recommended)

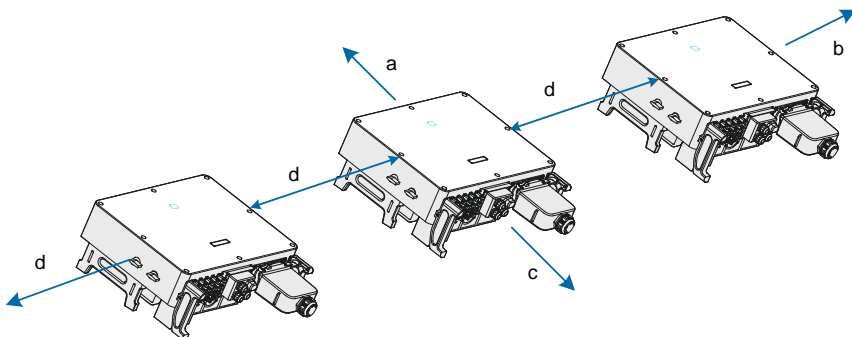

Table 5-2 Minimum spacing for inline installation (unit: mm)

Model	Top (a)	Right (b)	Bottom (c)	Middle (d)
SG25CX-SA SG30/33/40/50CX	500	200	650	600
SG36/60CX-US	500	200	650	450
SG100/110CX SG136TX	600	400	450	800

Front and rear installation

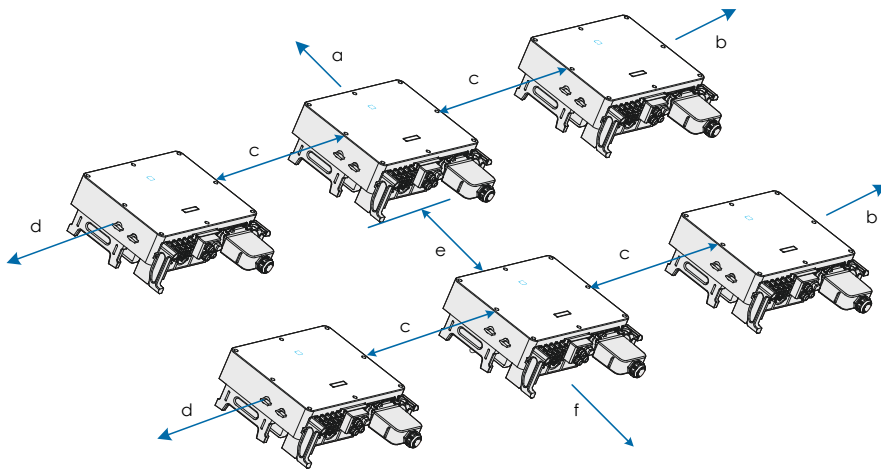

Table 5-3 Minimum spacing for front and rear installation (unit: mm)

Model	Top (a)	Right (b)	Middle (c)	Left (d)	Top and bottom spacing (e)	Bottom (f)
SG25CX-SA SG30/33/40/50CX	500	200	450	450	1000	650
SG36/60CX-US	500	200	450	450	1000	650
SG100/110CX SG136TX	600	400	800	800	1000	400

6 Sunshade

6.1 Top sunshade

The top sunshade is suitable for vertical rack mounting and wall-mounting scenarios.

6.1.1 Precautions

- In order to ensure good shading, we recommend that the front of the inverter is not exposed to the sun.
- The inverter air outlet may not be blocked.
- The sunshade design and selected materials should take wind, rain, snow, shock, and corrosion resistance into consideration.
- The sunshade can be fixed on the beam or wall where the inverter is mounted.

6.1.2 Sunshade dimensions

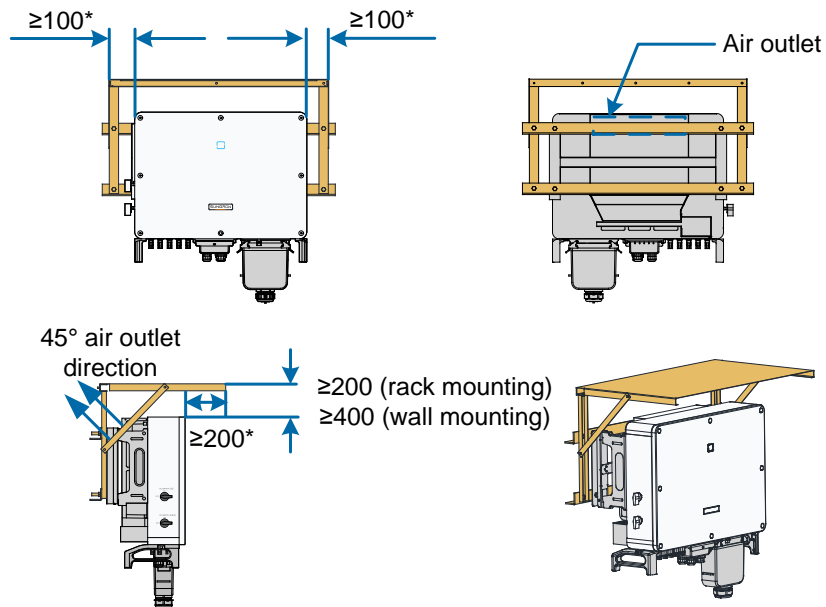

Fig. 6-1 SG25CX-SA/SG30CX/SG33CX/SG40CX/SG50CX sunshade dimension drawing (unit: mm)

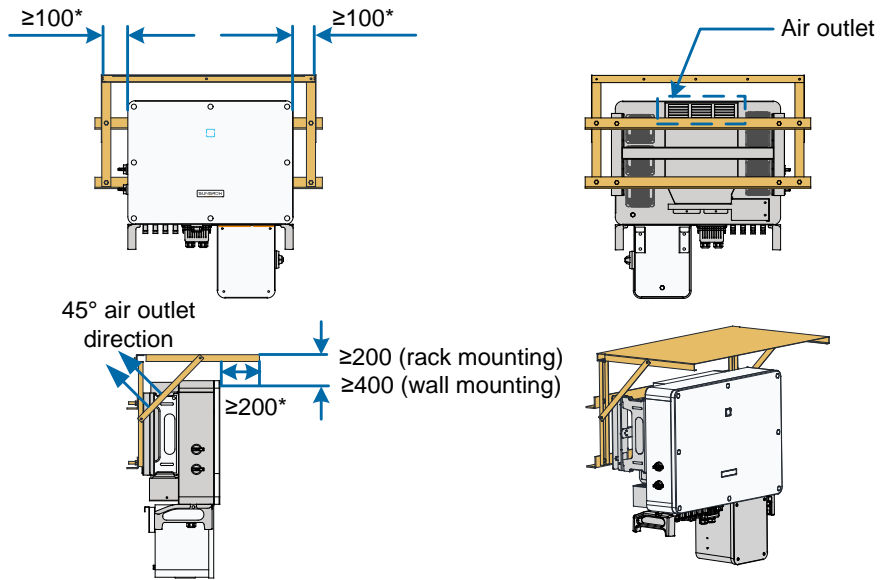

Fig. 6-2 SG36/60CX-US sunshade dimension drawing (unit: mm)

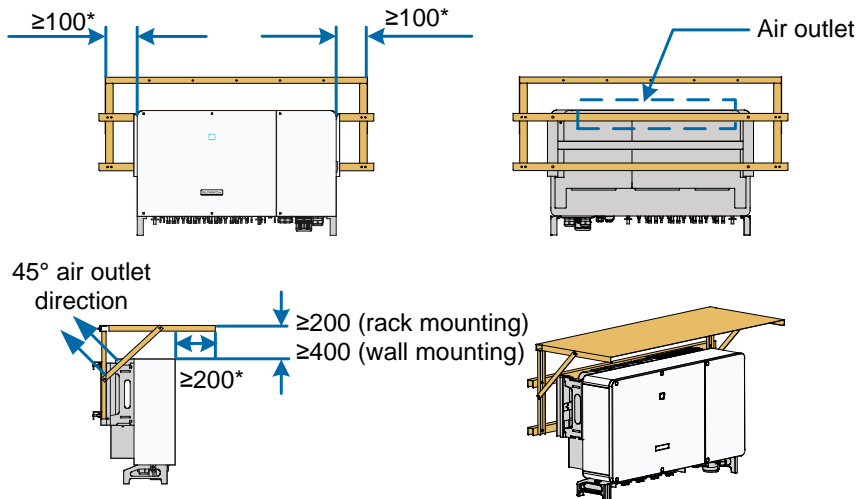

Fig. 6-3 SG100CX/SG110CX/SG136TX sunshade dimension drawing (unit: mm)

Note: Values marked with * are recommended values. Those not marked with * are mandatory values. Values can be adjusted according to the actual situation on site.

6.2 Flat Sunshade

Flat sunshades are suitable for inverters using the flat installation method.

6.2.1 Precautions

- The inverter air outlet may not be blocked.
- The sunshade design and selected materials should take wind, rain, snow, shock, and corrosion resistance into consideration.
- The sunshade can be fixed on the support beam or base where the inverter is installed.
- For ease of maintenance, the sunshade must be designed as a removable structure and must not be welded to the mounting rack.

6.2.2 Sunshade dimensions

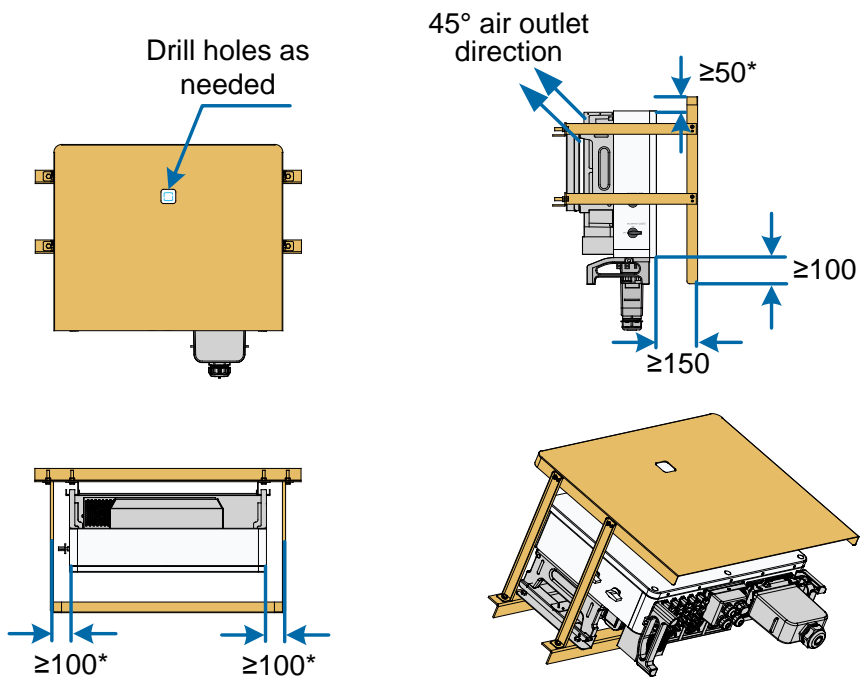

Fig. 6-4 SG25CX-SA/SG30CX/SG33CX/SG40CX/SG50CX sunshade dimension drawing (unit: mm)

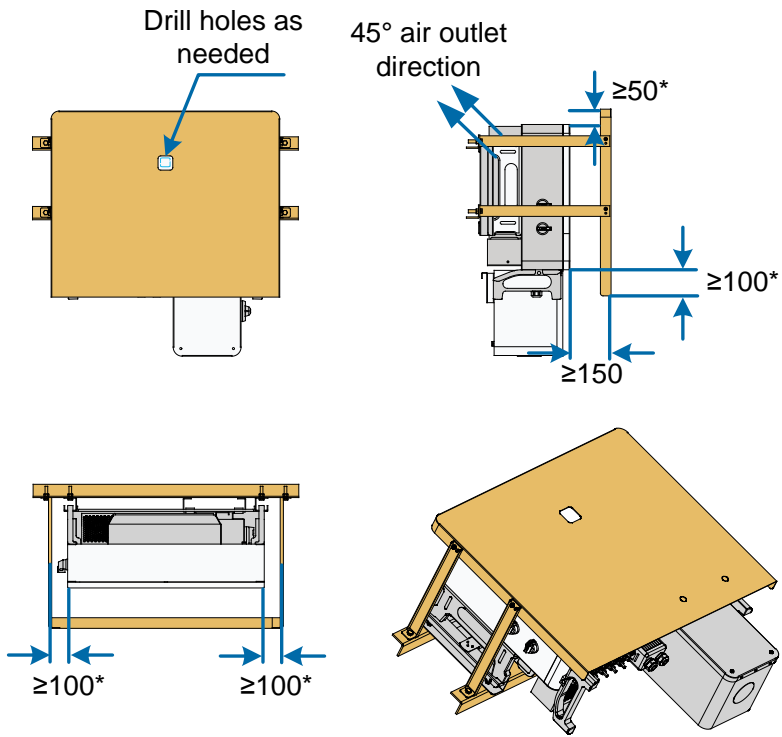

Fig. 6-5 SG36/60CX-US sunshade dimension drawing (unit: mm)

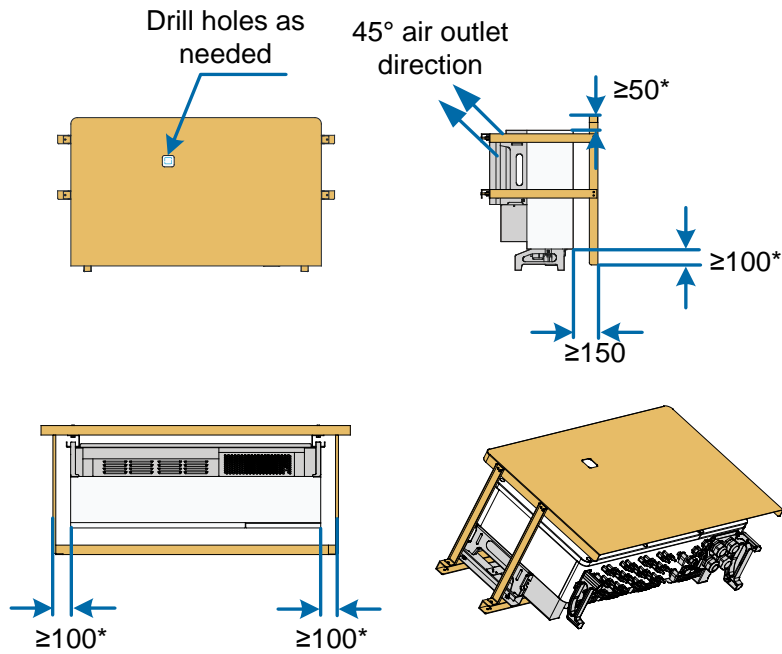

Fig. 6-6 SG100CX/SG110CX/SG136TX sunshade dimension drawing (unit: mm)

Note: Values marked with * are recommended values. Those not marked with * are mandatory values. Values can be adjusted according to the actual situation on site.

7 Appendix

7.1 Uncovering

For electrical wiring of the SG100CX/SG110CX/SG136TX models, the junction box must be uncovered. When installing the inverter, you must reserve enough space for electrical wiring and subsequent maintenance.

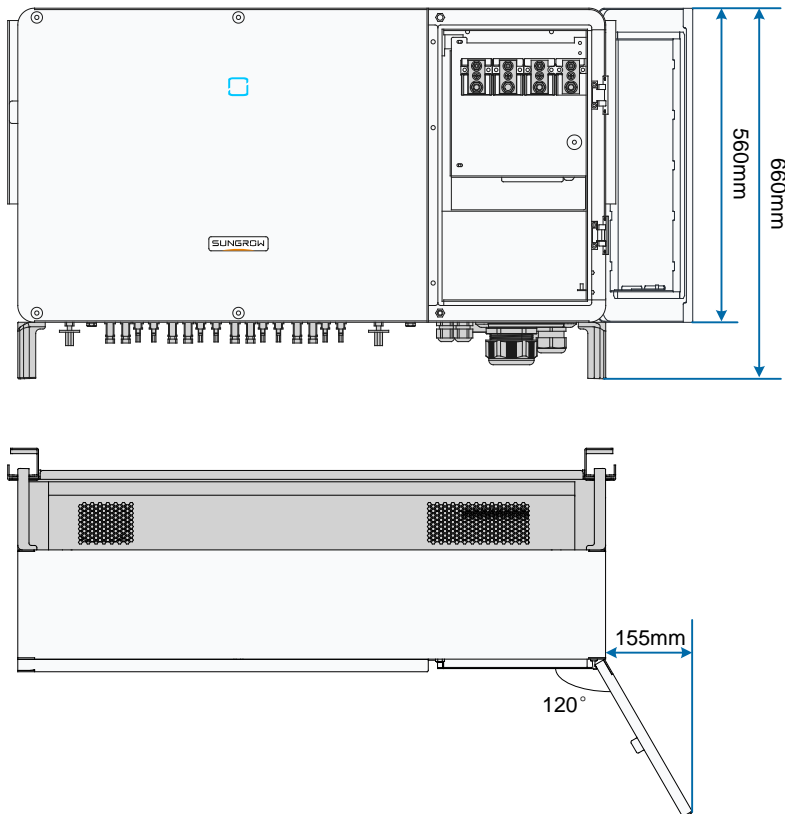

7.2 Fan Maintenance

For ease of fan maintenance, sufficient space must be reserved when installing the inverter.

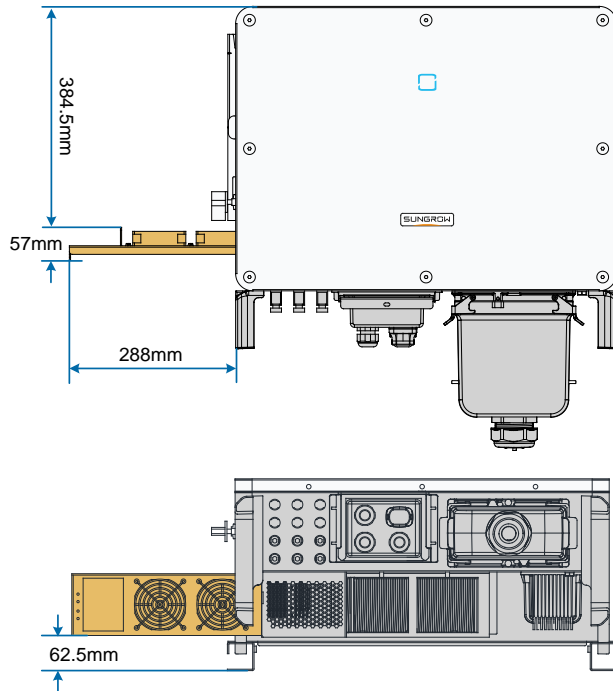

Fig. 7-1 SG30/33CX fan dimension drawing (unit: mm)

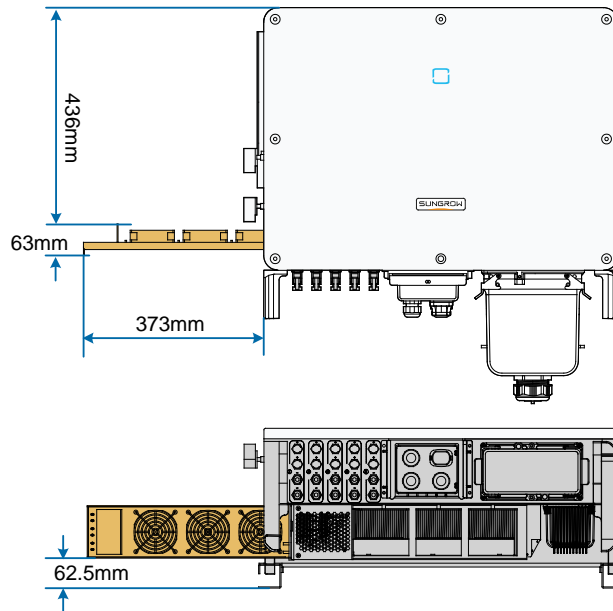

Fig. 7-2 SG25CX-SA/SG40CX/SG50CX fan dimension drawing (unit: mm)

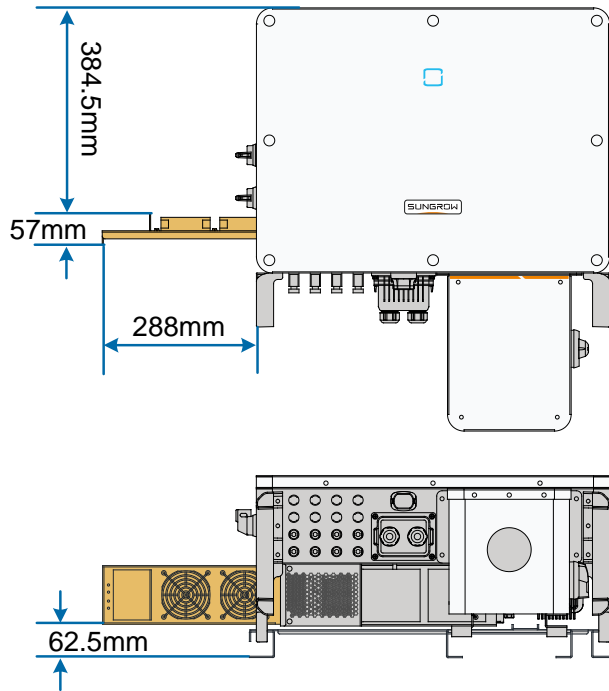

Fig. 7-3 SG36CX-US fan dimension drawing (unit: mm)

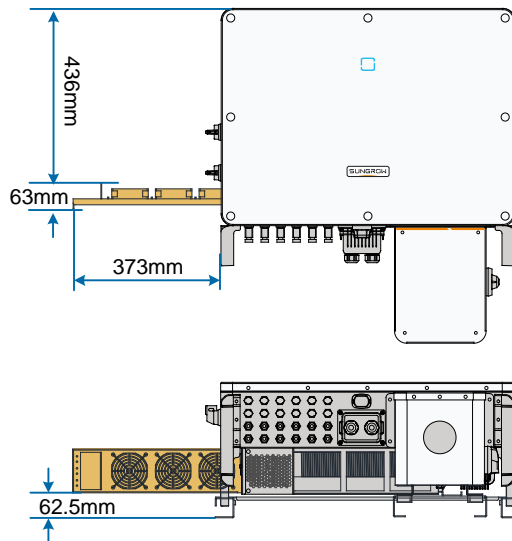

Fig. 7-4 SG60CX-US fan dimension drawing (unit: mm)

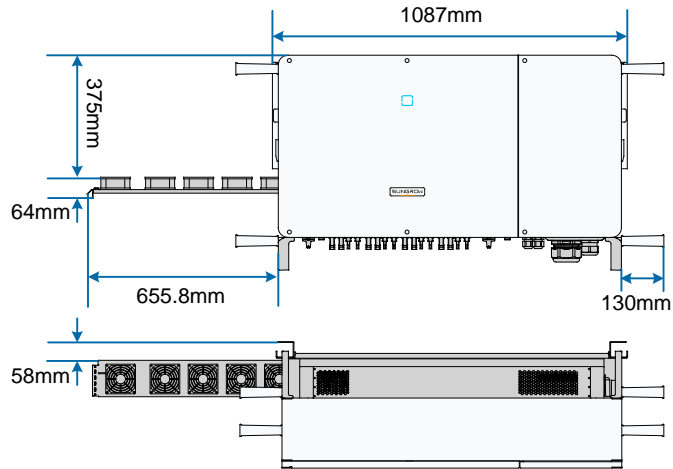
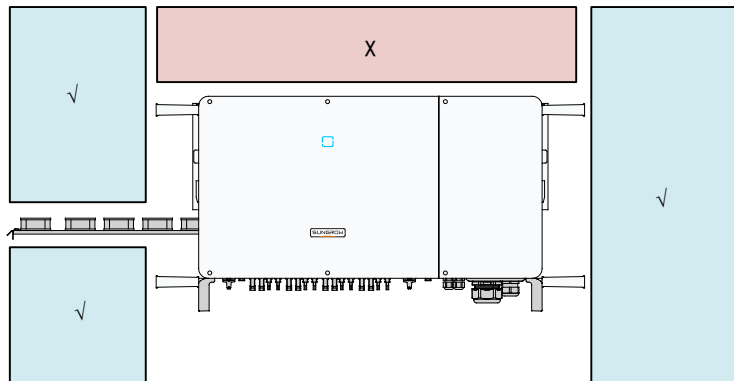

Fig. 7-5 SG100CX/SG110CX/SG136TX fan dimension drawing (unit: mm)

7.3 Spacing requirements for installing other devices

Because the air outlet is on the back of the inverter, when installing meters, small distribution boxes, and other devices near the inverter, you must reserve the necessary space according to the fan dimension drawing. Refer to the "7.2 Fan Maintenance" for the fan dimension drawing. No other devices may be installed near the inverter fan.



Note: X indicates that no other devices can be installed at this location. √ indicates that other devices can be installed at this location.